

Artificial Intelligence

Search Simulations

Dr. Ahmedul Kabir



Depth 1st Search

① **A**

[<A>]

②

[<T, A> <S, A> <Z, A>]

③

[<L, T, A> <S, A> <Z, A>]

④

[<M, L, T, A> <S, A> <Z, A>]

⑤

[<D, M, L, T, A> <S, A> <Z, A>]

⑥

[<C, D, M, L, T, A> <S, A> <Z, A>]

⑦

[<P, C, D, M, L, T, A> <R, C, D, M, L, T, A> <S, A> <Z, A>]

⑧

[<B, P, C, D, M, L, T, A> <R, P, C, D, M, L, T, A>
<R, C, D, M, L, T, A> <S, A> <Z, A>]

Goal!!

Breadth 1st Search

① **A**

[<A>]

[<T, A> <S, A> <Z, A>]

[<S, A> <Z, A> <L, T, A>]

[<Z, A> <L, T, A> <R, S, A> <F, S, A> <O, S, A>]

[<L, T, A> <R, S, A> <F, S, A> <O, S, A> <O, Z, A>]

[<R, S, A> <F, S, A> <O, S, A> <O, Z, A> <M, L, T, A>]

②
(
9) [<F, S, A> <O, S, A> <O, Z, A> <M, L, T, A> <C, R, S, A> <P, R, S, A>]

[<O, S, A> <O, Z, A> <M, L, T, A> <C, R, S, A> <P, R, S, A> <B, F, S, A>]

[<O, Z, A> <M, L, T, A> <C, R, S, A> <P, R, S, A> <B, F, S, A> <Z, O, S, A>]

[<M, L, T, A> <C, R, S, A> <P, R, S, A> <B, F, S, A> <Z, O, S, A> <S, O, Z, A>]

⑩
(
11) <C, R, S, A> <P, R, S, A> <B, F, S, A> <Z, O, S, A> <S, O, Z, A> <D, M, L, T, A>]

[<P, R, S, A> <B, F, S, A> <Z, O, S, A> <S, O, Z, A> <D, M, L, T, A>
<P, C, R, S, A> <D, C, R, S, A>]

[<B, F, S, A> <Z, O, S, A> <S, O, Z, A> <D, M, L, T, A>
<P, C, R, S, A> <D, C, R, S, A> <B, P, R, S, A> <C, P, R, S, A>]

Goal!!

Depth-Limited Search

(shown for limit = 5)

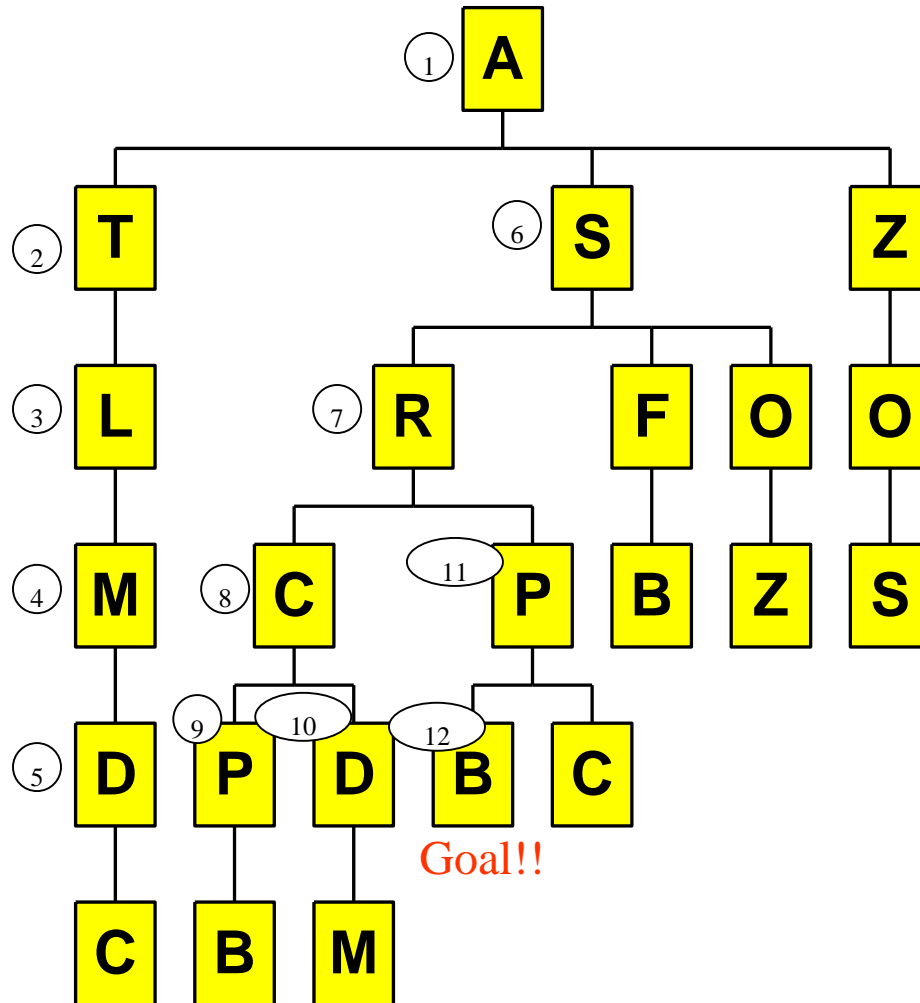

Iterative Deepening Search

Limit = 0



Limit = 1

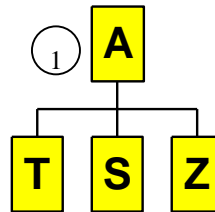

Limit = 2

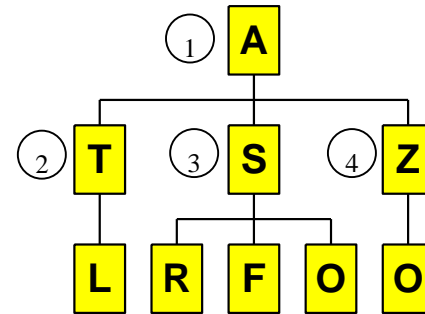

Limit = 3

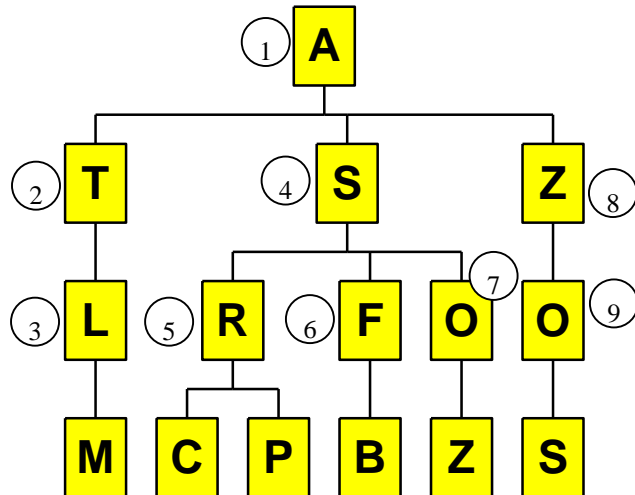

Limit = 4

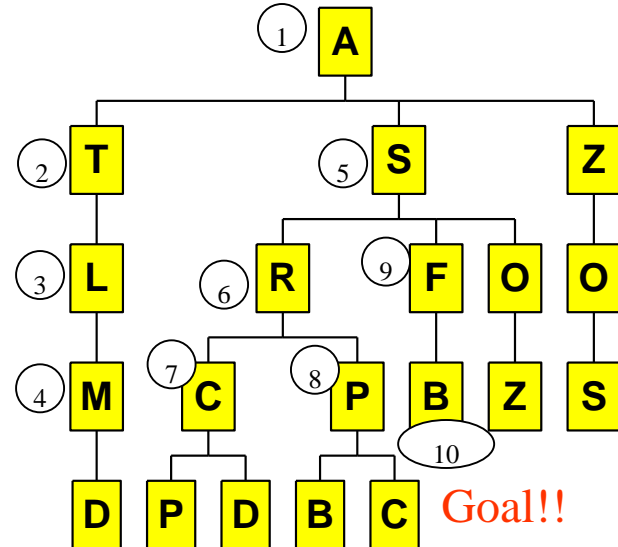

Uniform-Cost Search (= Branch-and-Bound Search)

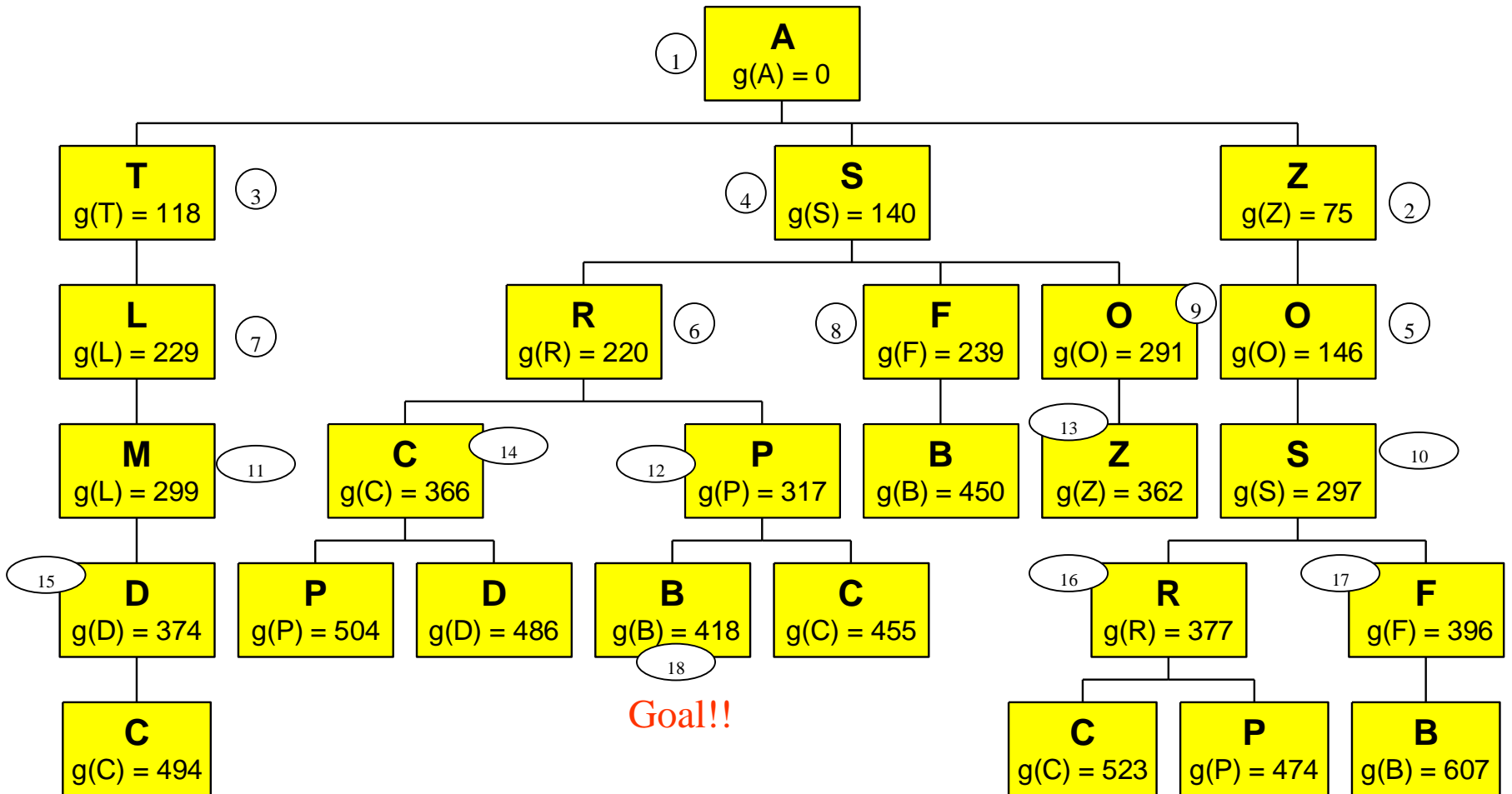

Greedy Search

(= Winston's Best 1st Search)

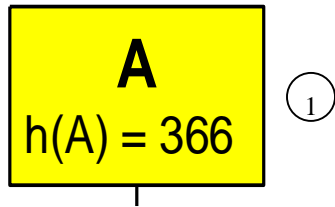

[366<A>]

②

[253<S, A> 329<T, A> 374<Z, A>]
* Newly inserted paths are shown in green

③

[178<F, S, A> 193<R, S, A> 329<T, A>
374<Z, A> 380<O, S, A>]

④

[0<B, F, S, A> 193<R, S, A> 329<T, A>
374<Z, A> 380<O, S, A>]

Goal!!

A* Search

A
g(A) = 0
h(A) = 366
f(A) = 366

①

[366<A>]

②

[393<S, A> 447<T, A> 449<Z, A>]

[413<R, S, A> 415<F, S, A> 447<T, A>
449<Z, A> 671<O, S, A>]

③

④

[415<F, S, A> 417<P, R, S, A> 447<T, A>
449<Z, A> 526<C, R, S, A> 671<O, S, A>]

⑤

[417<P, R, S, A> 447<T, A> 449<Z, A> 450<B, F, S, A>
526<C, R, S, A> 671<O, S, A>]

[418<B, P, R, S, A> 447<T, A> 449<Z, A> 450<B, F, S, A>
526<C, R, S, A> 615<C, P, R, S, A> 671<O, S, A>]

⑥ Goal!!